



The design of a secondary containment system requires the evaluation of several different factors; this tech note discusses what is required of the containment wall and the options that exist.

Secondary Containment systems for aboveground storage tanks in Alberta are primarily utilized by the upstream, midstream and downstream sectors of Alberta's Oil and Gas sector. Guidance for the design of a secondary containment system can be found in the Alberta Fire Code, under Alberta Municipal Affairs and Energy Resources Conservation Board (ERCB) Directive 55. The separation between the two being the containment of flammable or combustible liquids with a flash point less than 93.3⁰C falling under the Alberta Fire Code, while the containment of most other liquids at upstream petroleum sites are governed by Directive 55.

An excerpt from EUB Directive 55 reads:

A dike must:

- 1) be constructed of a material designed to contain liquids and to be able to withstand the hydrostatic head associated with it being full of liquid, and so that it will not deteriorate or develop leaks during the projected life of the structure;*
- 2) be sized to have a volumetric capacity of not less than 110 per cent of the capacity of the tank when the diked area contains one tank. When the diked area contains more than one tank, not less than the sum of;
 - a) the capacity of the largest tank located in the diked area, and*
 - b) 10 per cent of the greater of the capacity specified in (a), or the aggregate capacity of all other tanks located in the diked area;**

The three most common materials considered for the construction of secondary containment systems are steel, concrete, and earthen berms. Contain Enviro Services Ltd. has extensive geomembrane installation experience with all three materials and suggests that the material that is typically the most cost effective solution is the use of corrugated steel panels manufactured by Westeel.



Tech Note: Secondary Containment Design Considerations

Corrugated steel panels are light weight yet sturdy and can be easily transported and installed in any weather condition. Concrete systems are bulky, fragile, and heavy requiring large equipment to bring them to site and to install. Due to their weight, more invasive sub-grade preparation such as pilings may be required to minimize differential settlement of a concrete wall. Westeel's corrugated steel panels mount onto pads which "engage" the subgrade, this Zero Ground Disturbance system requires no posts to be driven and would not be a contributing factor to settlement.

The construction of earthen pits again requires the use of heavy equipment to move the soil to create the containment. This technique is very weather dependant, and requires a much larger footprint as a 4:1 slope leading into the containment is usually required to address constructability issues. Once the containment has been built, serious construction issues would arise if the containment would be required to be expanded, or worse, moved. Corrugated steel panels are assembled using high strength fasteners; nuts, bolts, and washers are used to construct the system, which can easily be disassembled to be expanded, moved, or modified in any way. More geomembrane liner can easily be welded to existing liner so as to expand any system quickly and efficiently.

To address the capacity requirements of Directive 55, Contain Enviro Services Ltd. stocks corrugated steel panels in four standard wall heights; 22", 33", 44" and 57". The addition of every panel adds 9.4 feet of effective length to the perimeter of the containment system. To address the hydrostatic loads the containment system may face, 22" and 33" wall panels require the support of 3 pads, and braces for every 2 wall panel sections, 44" wall panels require 2 pads and braces per panel while the 57" wall panel sections require 3 pads and braces per wall panel section.

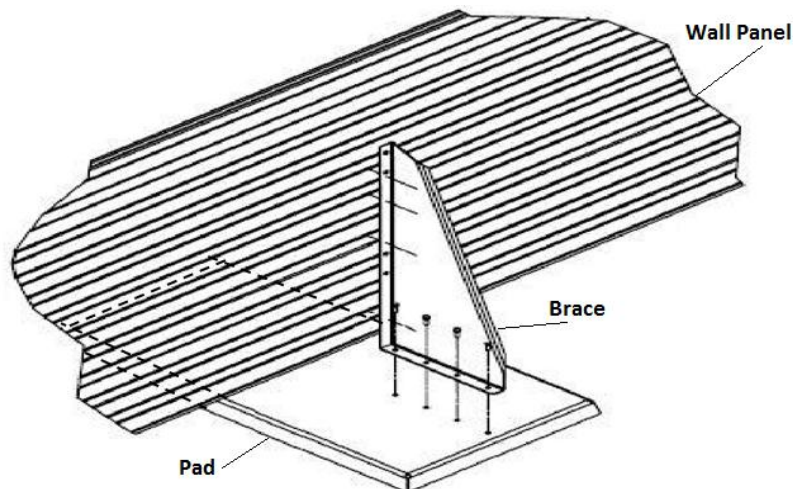

The corrugated steel containment system is installed with the required geomembrane, covered by a layer of geotextile and backfill over the liner. This backfill is typically a 3" layer of sand or screened sand which consists of a 3/8" minus aggregate.

Contain Enviro Services Ltd. is the leader in the supply and installation of corrugated steel containment systems for use as primary or secondary containment in a wide variety of challenging applications, and can provide you with the design support to deal with your most demanding application.

For More Information, Please Visit Our Website www.contain.ca